

BLDC PUMP

Automobile Water Pump



Rated Voltage: DC 12V/24V
Max Static Head: 10M / 12M
Max Flow rate: 3000LPH / 3300LPH
Input Power: 80W/100W
Inlet Outer Diameter: 20mm
Outlet Outer Diameter: 20mm
Size: 141.3x100x118mm
Weight: about 900g
Material: PA66+30%GF
Waterproof: IP68
Noise: less than 40dB
Liquid Temperature: -40~125°C

Design special for the cooling system of the automobile battery, automobile engines, and motorcycle engines. Also suitable for other applications.

Main Features

- Sine Wave Silent Technology, Noise less than 40dB;
- Default with water shortage and stuck protection functions;
- Brushless DC motor, Magnetic Driven, Small size & High Efficiency;
- Long time continuous working, lifespan more than 20000 hours;
- Safety - no spark, Explosion-proof, IP68, 100% waterproof;
- Can be used to pump water, oil, acid and alkali solution.

Model Code

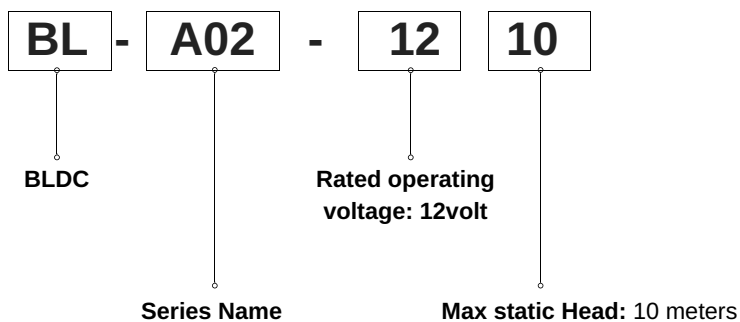

Mode List

Model	Voltage (V)	Current (A)	Max flow (L/H)	Max head (M)
BL-A02-1210	12	6.7	3000	10
BL-A02-2412	24	4.0	3300	12

Tips:

We offer customized service according to your specific needs at a reasonable price.

Performance Curve

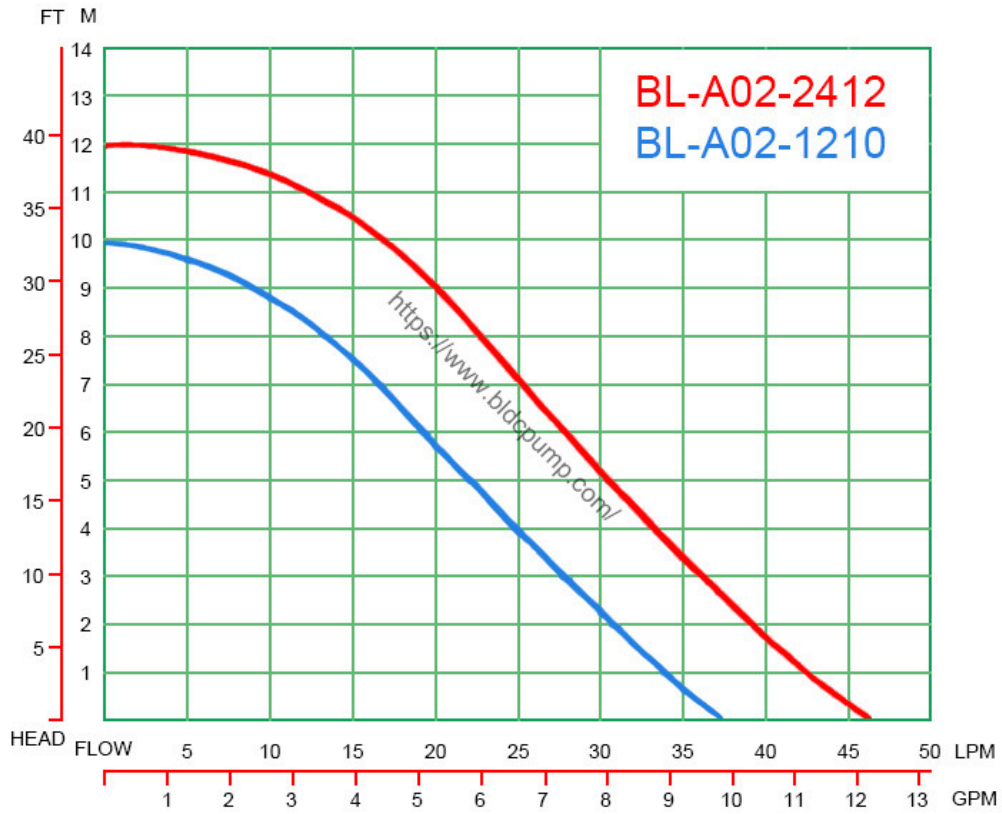

Dimensions

